

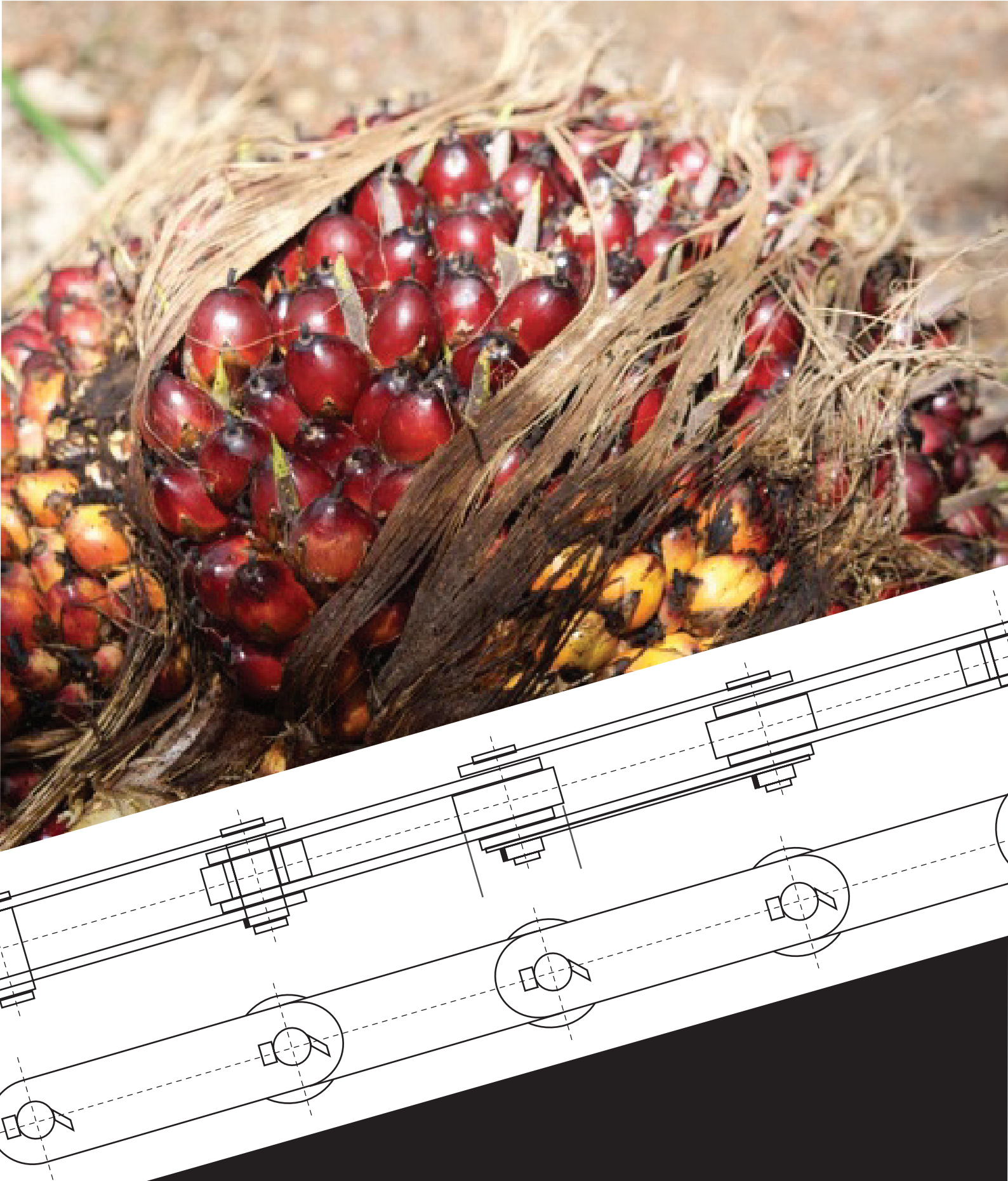

DYNRA

PRIVAND
PALM OIL MILL CHAIN

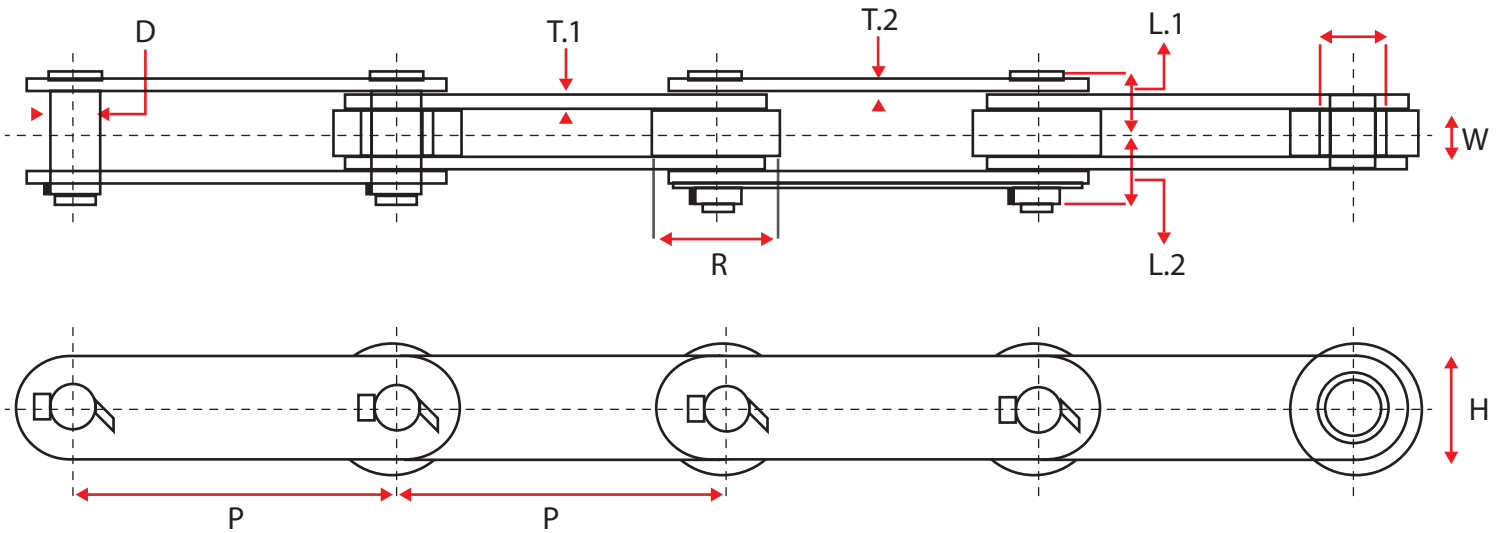



CHAIN SOLID T-PIN TYPE

Dyna Chain No.	Pitch (P)	Inner Width (W)	Roller Dia. (R)	Pin Dia. (D)	Bushing	L1	L2	Plate Height (H)	Plate Thickness T1	Plate Thickness T2	Minimum Load	Weight kg/m
DY426R-TP/RP	101.6	19.0	47.6	19.0	O	24.1	30.1	38.1	5.1	5.1	26.000 lbf	6.9
DY436R-TP/RP	101.6	19.0	47.6	19.0	O	28.7	29.5	35.1	6.3	6.3	36.000 lbf	7.5
DY445R-TP/RP	101.6	19.0	47.6	19.0	D	28.7	29.5	38.1	6.3	6.3	45.000 lbf	7.8
DY465R-TP/RP	101.6	25.4	66.7	22.0	D	35.5	42.5	50.8	7.1	6.3	45.000 lbf	14.6
DY645R-TP/RP	152.4	25.4	66.7	22.0	O	35.5	42.5	50.8	6.3	6.3	45.000 lbf	10.5
DY650R-TP/RP	152.4	25.4	66.7	26.9	O	37.0	44.0	50.8	7.8	7.8	50.000 lbf	12.9
DY670R-TP/RP	152.4	25.4	66.7	26.8	O	37.0	44.0	50.8	9.5	8.0	70.000 lbf	15.0

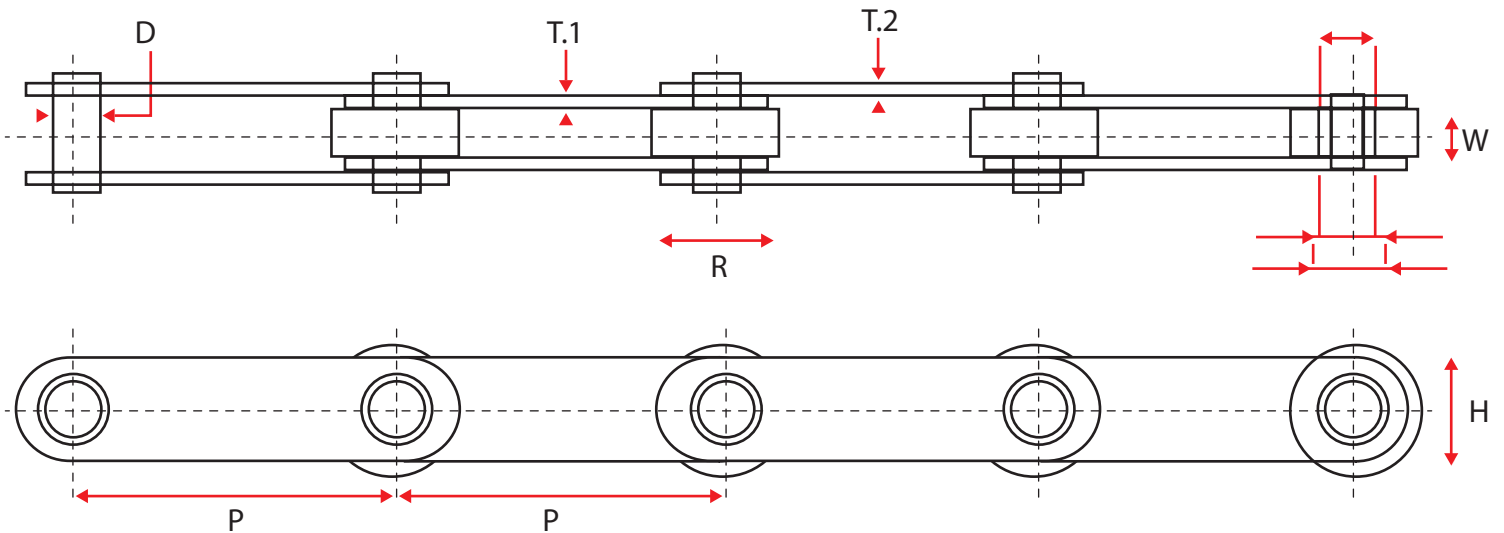

CHAIN HOLLOW PIN CHAIN TYPE

Dyna Chain No.	Pitch (P)	Inner Width (W)	Roller Dia. (R)	Outer Bushing (D)	Inner Bushing (d)	Bolt/ Nut	Plate Height (H)	Plate Thickness T1	Plate Thickness T2	Minimum Load	Weight kg/m
DY428 HP	101.6	19.0	47.6	19.1	13.2	M 12	39.4	6.3	5.1	28.000 lbf	7
DY464 HP	101.6	25.4	66.7	26.9	19.6	M 18	50.8	7.1	5.1	45.000 lbf	13.5
DY636 HP	152.4	25.4	66.7	26.9	20.7	M 20	50.8	6.3	6.3	36.000 lbf	9.7
DY660 HP	152.4	25.4	66.7	26.9	19.6	M 18	50.8	7.8	7.8	60.000 lbf	11.65

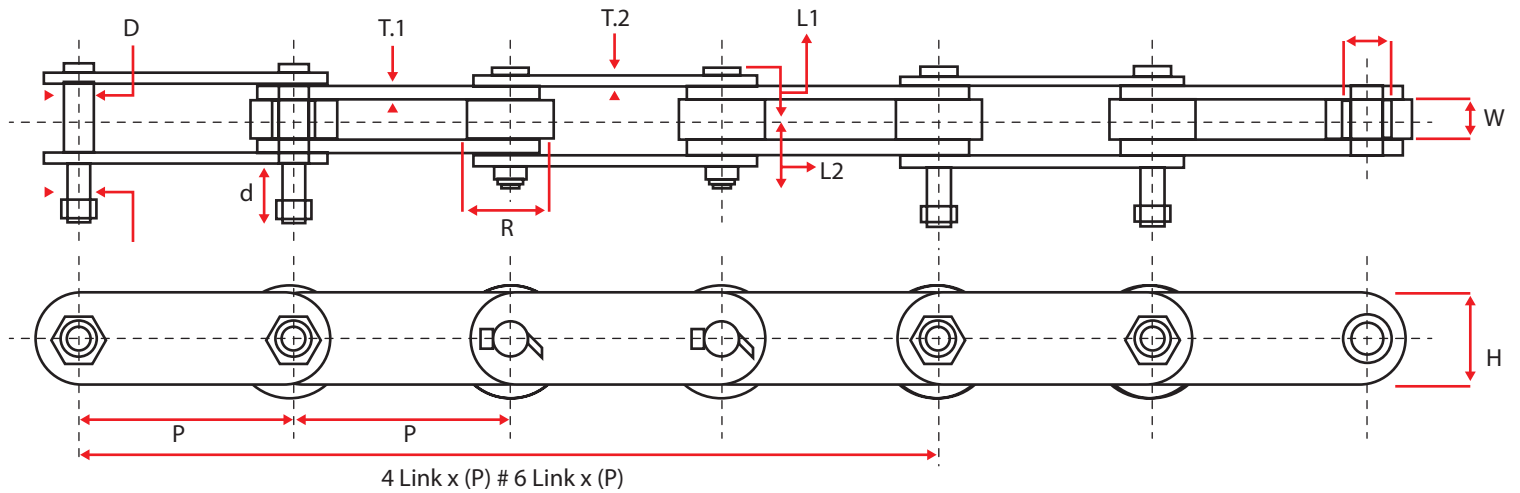

CHAIN SOLID EXTENDED PIN WITH LOCK NUT TYPE

Dyna ChainNo.	Pitch (P)	Inner Width (W)	Roller Dia. (R)	Pin Dia. (D)	Bushing	L1	L2	L3	Plate Height (H)	Plate Thickness T1	Plate Thickness T2	Minimum Load	Weight kg/m
DY426R-4LEP/6LEP	101.6	19.0	47.6	19.0	○	24.1	30.1	82.0	38.1	5.1	5.1	26.000 lbf	7.55/7.45
DY436R-4LEP/6LEP	101.6	19.0	47.6	19.0	○	28.7	34.7	87.0	35.1	6.3	6.3	36.000 lbf	8.6/8.3
DY445R-4LEP/6LEP	101.6	19.0	47.6	19.0	D	28.7	34.7	87.0	38.1	6.3	6.3	45.000 lbf	8.7/8.4
DY645R-4LEP/6LEP	152.4	25.4	66.7	26.9	○	35.5	42.5	96.8	50.8	6.3	6.3	45.000 lbf	12.5/11.5
DY650R-4LEP/6LEP	152.4	25.4	66.7	26.9	○	38.5	45.5	110.0	50.8	7.8	7.8	60.000 lbf	14/13
DY670R-4LEP/6LEP	152.4	25.4	66.7	26.9	○	41.9	48.9	113.0	50.8	9.5	8.0	70.000 lbf	16/15
DY6130R-4LEP	152.4	37.4	69.9	20.8	D	44.0	52.7	135.5	54.0	9.5	9.5	130.000 lbf	19.0

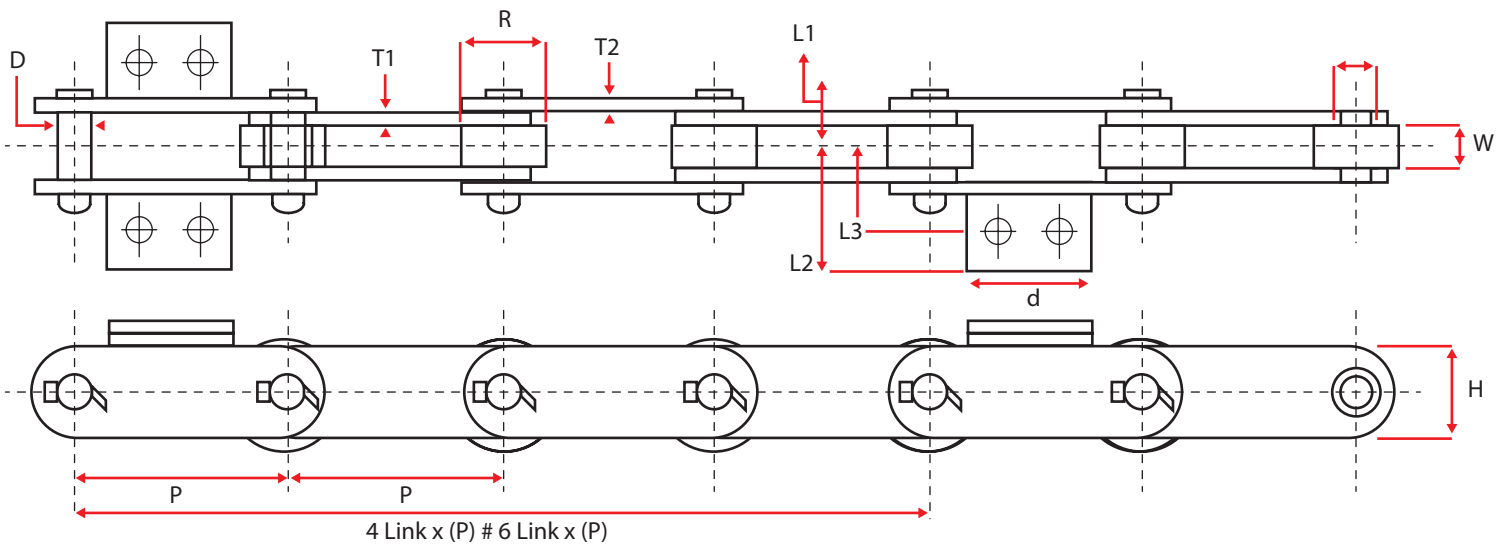

CHAIN SOLID PIN WITH ATTACHMENT TYPE (BK24 / SK2)

Dyna Chain No.	Pitch (P)	Inner Width (W)	Roller Dia. (R)	Pin Dia. (D)	L1	L2	L3	Plate Height (H)	Plate Thickness T1	Plate Thickness T2	Minimum Load	Weight kg/m
DY426R-4LSK2/6LSK2	101.6	19.0	47.6	19.0	24.1	31.2	44.5	38.1	5.1	5.1	26.000 lbf	8.1/7.85
DY426R-4LBK24/6LBK24	101.6	19.0	47.6	19.0	24.1	68.0	44.5	38.1	5.1	5.1	26.000 lbf	9/8.41
DY436R-4LSK2/6LSK2	101.6	19.0	47.6	19.0	28.7	31.2	44.5	35.1	6.3	6.3	36.000 lbf	9.23/8.8
DY436R-4LBK24/6LBK24	101.6	19.0	47.6	19.0	28.7	68.0	44.5	35.1	6.3	6.3	36.000 lbf	10.2/9.6

PT HASEN JAYA BERSAMA
LTC Glodok Lt. 2 Blok C8 No. 7
Jl. Hayam Wuruk No. 127 Jakarta Barat 11180